

PERFECT SOLUTIONS FOR ALL WORKPLACES

MOBILE WORKSTATIONS FROM LISTA



making workspace work

ROYAL *Variset*
Tool Management Systems

LISTA

WORK SUCCESSFULLY IN ANY ENVIRONMENT

Defence, security, off-shore, construction and heavy industry: there are many sectors in which work is carried out in confined and harsh conditions. The demands are also high in racing or radio and television broadcasts. Mobile workstations from LISTA are the ideal solution. This seamless modular system is ideal for a wide range of individual applications for diverse tasks and extreme environments. Elaborate security and safety features ensure full functionality in any environment.



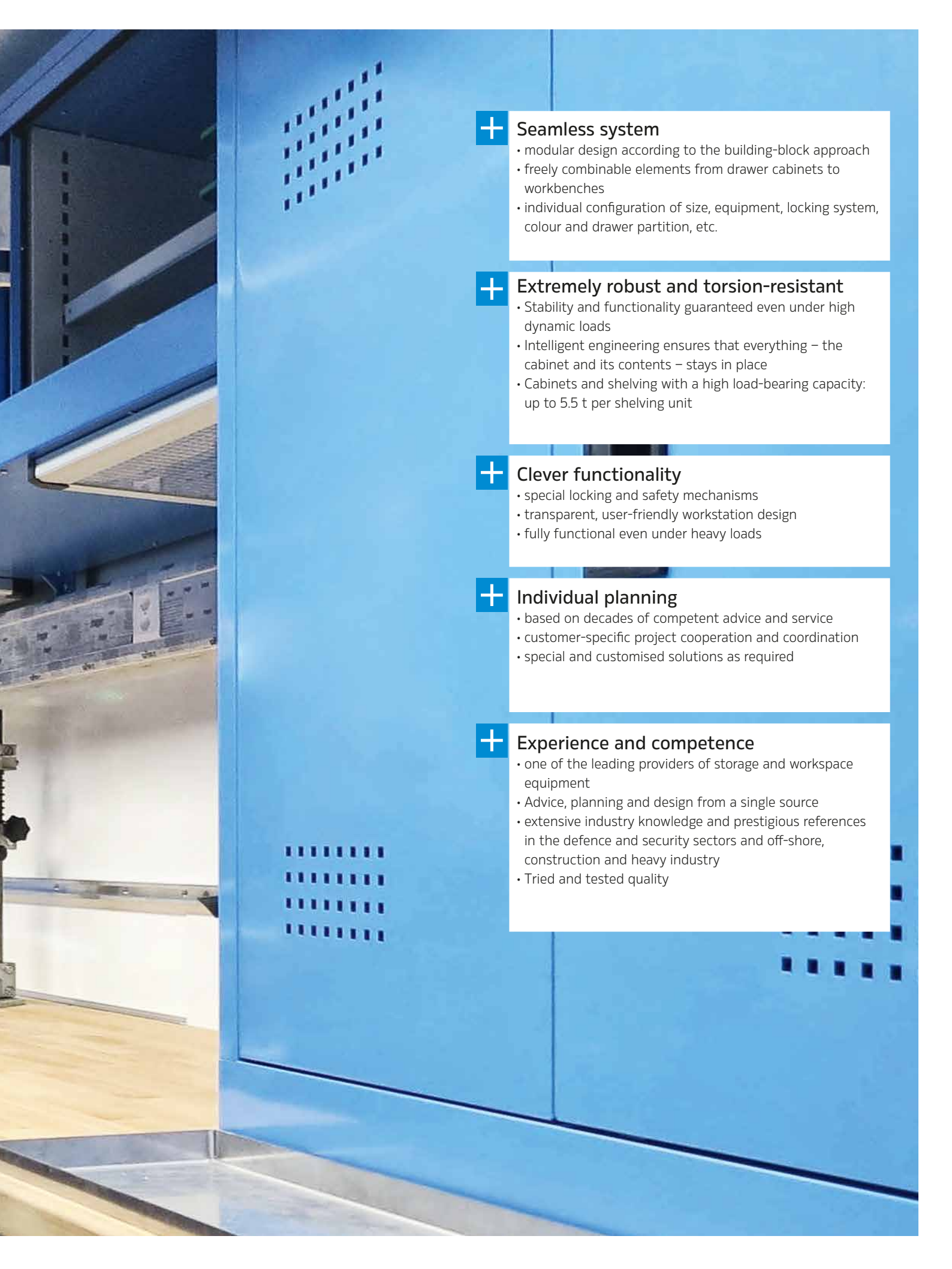

+ Seamless system

- modular design according to the building-block approach
- freely combinable elements from drawer cabinets to workbenches
- individual configuration of size, equipment, locking system, colour and drawer partition, etc.

+ Extremely robust and torsion-resistant

- Stability and functionality guaranteed even under high dynamic loads
- Intelligent engineering ensures that everything – the cabinet and its contents – stays in place
- Cabinets and shelving with a high load-bearing capacity: up to 5.5 t per shelving unit

+ Clever functionality

- special locking and safety mechanisms
- transparent, user-friendly workstation design
- fully functional even under heavy loads

+ Individual planning

- based on decades of competent advice and service
- customer-specific project cooperation and coordination
- special and customised solutions as required

+ Experience and competence

- one of the leading providers of storage and workspace equipment
- Advice, planning and design from a single source
- extensive industry knowledge and prestigious references in the defence and security sectors and off-shore, construction and heavy industry
- Tried and tested quality

ALWAYS READY TYPICAL INDUSTRIES AND APPLICATIONS

Whether military operation or research mission, construction site or off-shore installation: every application has its own demands. The LISTA system enables mobile workstations to be configured to suit

industry-specific criteria and perfectly tailored for any task. Working efficiently and successfully is what really counts at the end of the day.



Off-shore industry



Heavy duty



Structural and civil engineering



Defence and security

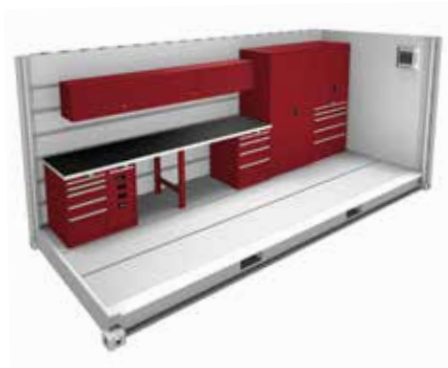

Workshop and maintenance
Optimal fastening even under high dynamic loads, secure storage and optimal use of space



Warehouse
High storage density and maximum transport security for stored items such as tools or spare parts. All stored items are protected and secure during transport.



Office or laboratory
Working on site without compromising on function and ergonomics as well as optimal protection of devices and material



Further applications
Flexible container solutions due to modular design, robust construction and individual configuration options



Free configuration without containers
Wide range of applications also without containers, on trailers, trucks, ships and other mobile applications

BIG IN SMALL SPACES

MODULES AT A GLANCE

The LISTA system includes a wide range of durable and robust workspace and storage equipment. All elements can be freely combined, individually configured and adapted to diverse specifications if required. Whatever you furnish: the result is exactly what you are looking for.



Test and inspection workstations
as a compact office or PC unit with power connection, dust cover and storage space



Drawer cabinets
variable and flexibly configurable cabinet and drawer size, equipment, locking system and colour, drawers with a load capacity of up to 200 kg



Workbenches
with a load capacity of up to 3 t, variable size, workbench surface, number of drawers and dimensions, ergonomically height-adjustable

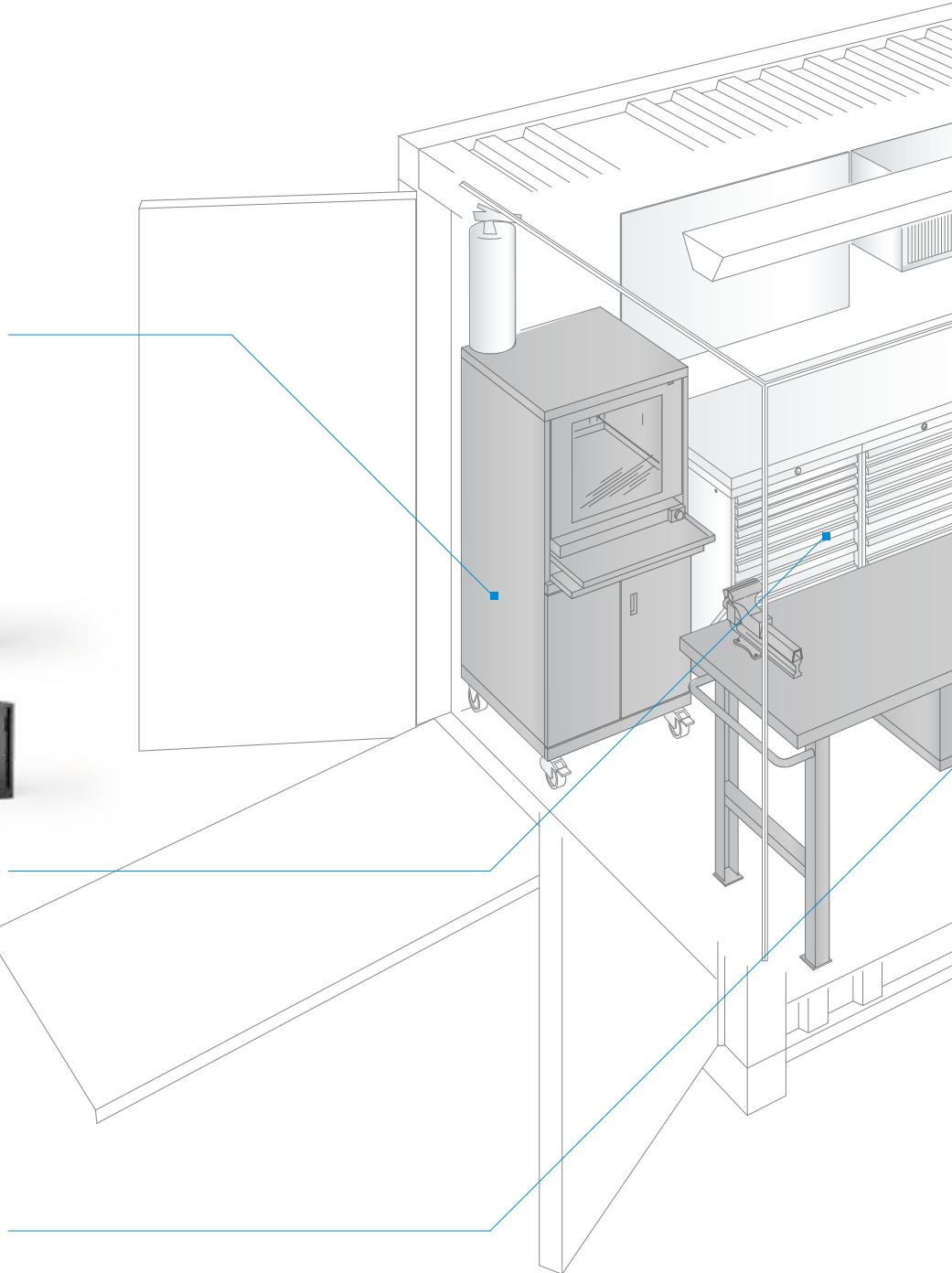

+ Seamless system

- Extremely robust and torsion-resistant design
- Secure storage of items for transport
- Functionality ensured even under high dynamic loads

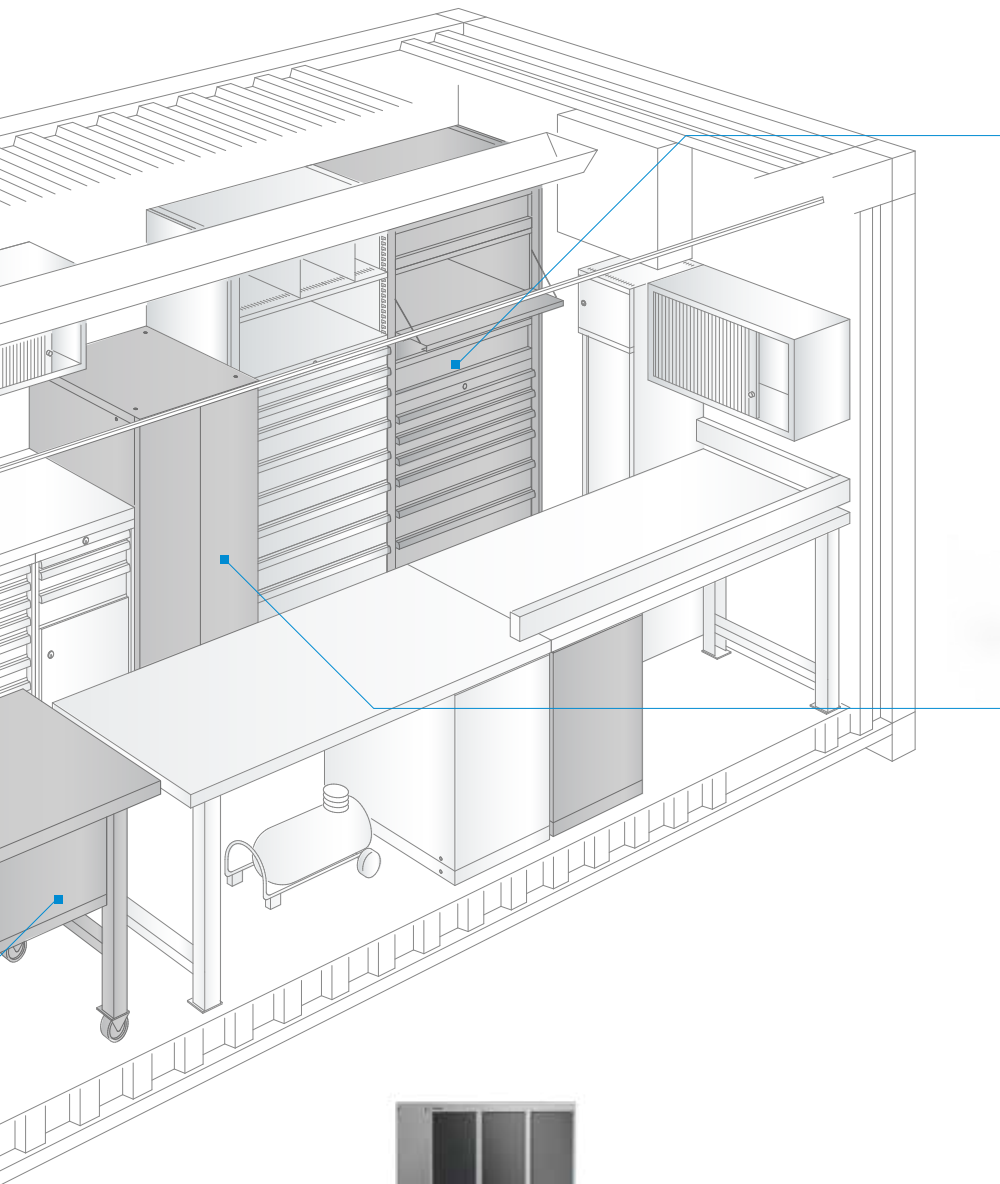

Drawer storage walls and shelves
in variable dimensions and equipment options with a load capacity of up to 5.5 t per shelving unit and 350 kg per pull-out or 475 kg per universal shelf



Vertical pull-out cabinets
for secure and space-saving storage of high and narrow storage items



Clothes lockers
for secure storage of functional clothing, shoes, equipment and personal items



Heavy-duty shelves
in a particularly solid design with a load capacity of up to 9 t per shelving unit and 1000 kg per fixed or pull-out frame, secure locking and adaptable in increments of 100 mm

PERFECTLY ADAPTED ADVANTAGES IN DETAIL

Mobile workstations are often subject to extreme conditions
At LISTA, we know what use under tough conditions means and we have designed our products to function reliably even in the most adverse environments.

Container-specific solutions



Optimal fastening

LISTA modules on horizontal rails ensure functionality and stability even under high dynamic loads



Reliable supply

with connections for compressed air and power



Special container equipment

Insulation, air conditioning, functional flaps, floor properties, fastening rail system and other configuration options, individually tailored to suit the specific purpose



High load capacities

up to 200 kg per drawer or 475 kg per universal shelf for storing heavy items, devices and tools



Screwed dividers and slotted partitions

For easy subdivision of drawers, secure transport and better arrangement of stored items



Reliable drawer safety catch

Prevents accidental opening, available as single, double and LiLo locking device (for locking drawers in an open and closed position)



Secondary additional locking

by means of a vertical locking bar for locking hinged and drawer fronts as an option



Optional load securing

by means of pull-out shelves with additional eyelets for fixing material and items to be transported



Precisely fitting partition material

such as plastic boxes, troughs or foam inserts for optimal protection during storage and transport



Electronic locking system

with LISTA Electronic Control for protecting particularly valuable parts at cabinet, drawer or compartment level



Robust full coating

complete cabinets and shelving against extreme loads



Free choice of colours

from 18 standard colours, other colours available on request

ADVICE AND PLANNING PROFESSIONAL LIKE YOU

At LISTA, your project is in the best hands. We are familiar with the demands on mobile workstations and take the time to deal with your individual needs and requirements. On this basis, we develop customer-specific solutions, which enables you to concentrate fully

on your work. Planning is based on the LISTA system, which can be complemented with special solutions if required. In addition to advice, planning and visualisation, we also carry out installation and service.

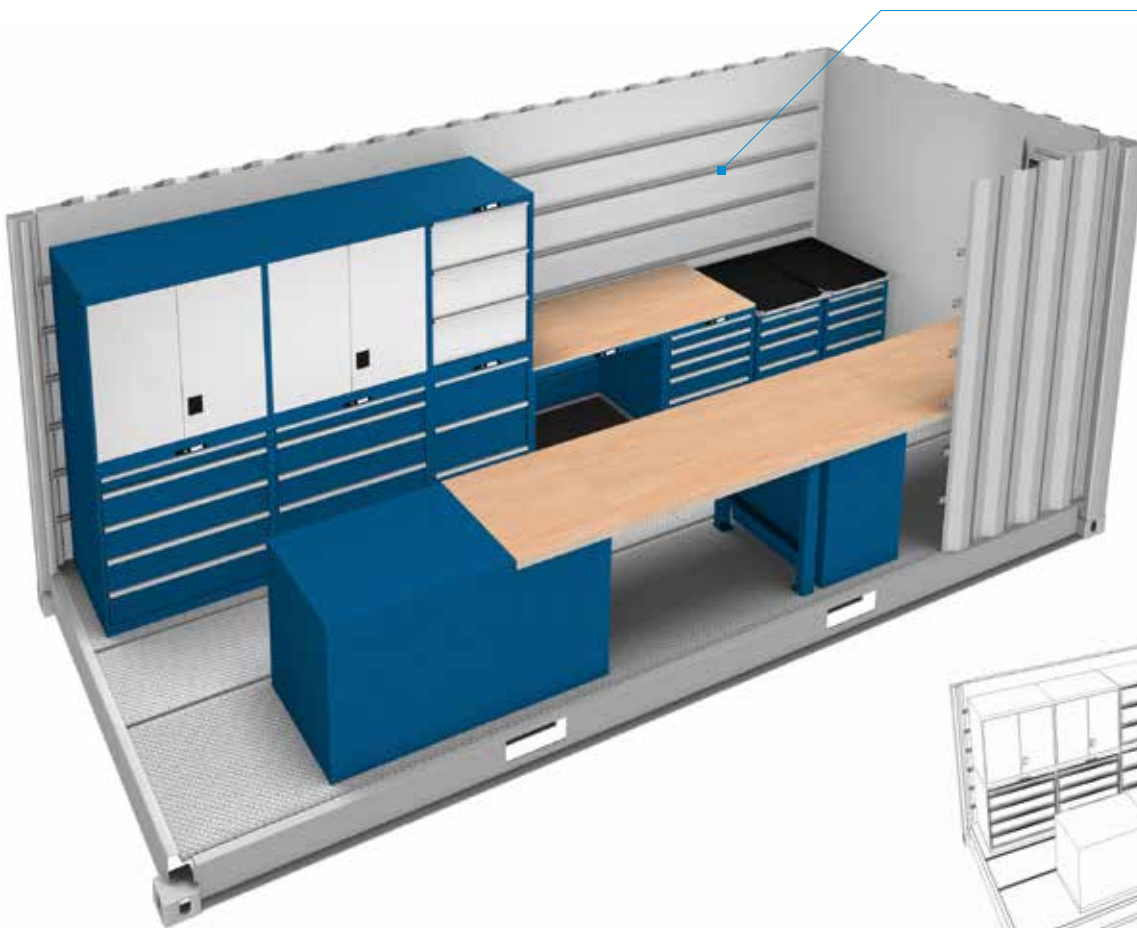

Flexible Rail system Versatile
horizontal rails for secure fastening of modules allows for individual container layout and equipment options.

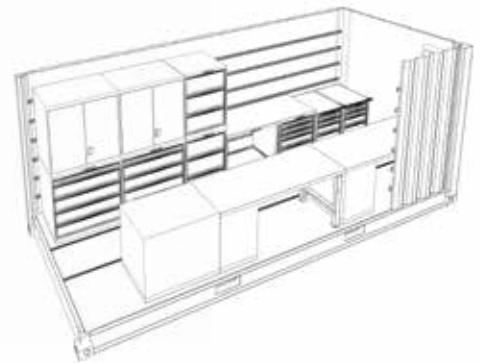

Countless configuration options

With the LISTA system, you can configure a workstation to suit your needs. Individual configuration creates an efficient and ergonomic environment. Maximum use is made of the available space. LISTA solutions can also be flexibly adapted and extended at any time due to its modular design.

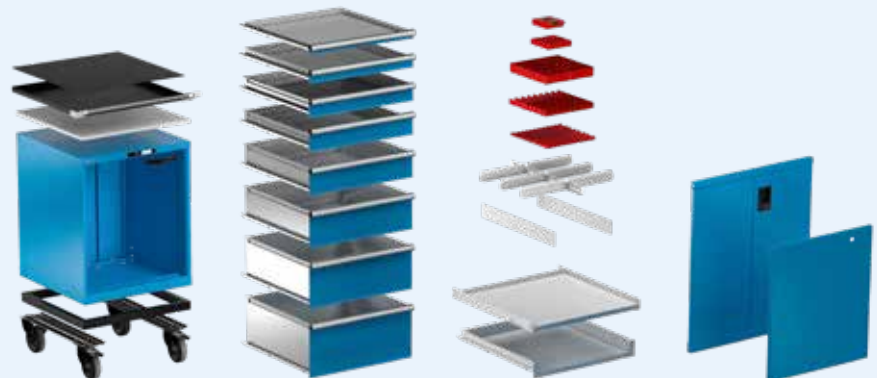

WITH LISTA ON THE MOVE MOBILE WORKSTATIONS IN PRACTICE

From military to racing: mobile furnishings and enlargements from LISTA have shown to be highly reliable in daily use. Even in harsh environments and extreme situations, the system does what it promises: full function without compromise.



LISTA AS A PARTNER WELCOME TO THE NO.1

LISTA offers organisation. With success, experience and system. For more than 70 years, we have offered our customers concepts for more organised and efficient working. Because we offer more than just a high-quality product, competent advice and a wide range of

services: the LISTA system creates perfect interlocking solutions for smooth workflows. And this makes us a leading partner in the area of workspace and storage equipment worldwide.



+ Comprehensive, extremely robust range of products

A complete range of products at a consistent quality standard: the best.

+ One system, countless possibilities

due to freely combinable modules

+ Tailor-made solutions

for customers with specific requirements

+ Maximum flexibility

with free choice of colours, configuration options and more

+ Wide range of services

including training, assembly, labelling, etc.

+ Competent planning

individually and precisely fitting

+ Worldwide distribution and service network

for customer support without boundaries

+ First-class references

from more than 100,000 prestigious companies worldwide



Supplied by:-

Royal Tool Control Ltd.
Amberley Court, Bold Street
Sheffield, UK, S9 2LQ
+44(0)114 2441411
www.royaltool.co.uk



www.lista.com