

Toolmaster TM10

Tool Presetters

Quick tool changes result in measurable success

TOOL MASTER 10

pub
SWISS

pub
SWISS

Simple, rapid, accurate



High performance in affordable compact class

Toolmaster 10 is the user-friendly tool presetter for the workshop. Take advantage of its high measuring reliability, ease of operation and unbeatable price.

It is a space saver, can be located virtually anywhere and meets the most exacting requirements. The time gained in re-tooling your machines will provide higher efficiency and productivity.

Pre-loaded recirculating ball guides on all axes and weight counter-balance ensure accurate and tireless operation. Measuring column and tool spindle are mounted on a thermally stabilized and stress-free cast-iron base. Bellows protect the guides, fine adjusting spindle and measuring system against rough workshop environments.

An additional sealed housing protects the glass measuring scales in any production environment. The 1 micron resolution of the scales ensures highest measuring reliability.

Measuring results are shown in large digits on displays with background lighting. Operation is dialogue guided and requires no special training.

The measuring accuracy for both axes (diameter and length) is greatly increased by the electronic axis parallelism compensation (electronic angle correction).

A high content of in-house produced parts together with selected quality components from leading suppliers guarantee long-lasting, reliable performance.

Design features of Toolmaster



- Ergonomic positioning of operating elements
- Single-handed operation of measuring carriage
- Optimum arrangement with selective axis clamping
- Infinite fine adjustment with micron accuracy
- Pre-loaded linear guides, protected by bellows guarantee long life with constant accuracy
- No compressed air required



Patented Tool Spindle

- Plastic cage protects tool spindle from damage
- Runout accuracy within microns
- Alternatively ISO40 or ISO50 taper
- Prevents measuring errors if tool holders are not brand new (dirty or damaged)
- Long-lasting, reliable performance
- Adapters for all commercially available tool holders

TM10-2D Dial Indicator



Probe measuring of cutting edge:

- A precision guided carbide probe for X- and Z-axes
- Shock absorbing safety dial indicator with free stroke for zero setting
- Constant measuring pressure of <math><1\text{N}</math> to protect cutting edge
- Ideal for establishing diameter and length

Measuring Electronics TC 100 Compact intelligence



- Glass scales AcuRite, resolution 0.001 mm (0,00004")
- 6" LCD display
- Extremely simple operation
- Dirt resistant soft key pad
- Dialogue in English/German/French/Italian/Spanish
- 99 reference point memory for different adapters and machine zero points
- Designation and counting direction freely selectable for each reference point
- Tool library for 500 tools
- Absolute/incremental measuring
- Hold function

TM10-P Projector



- Projector «swiss made» providing high contrast, minimum distortion and even illumination for non-tiring and error free measuring
- Diameter 110 mm (4,33")
- Magnification 20-X
- Fixed and rotatable reticule
- Extended life of halogene illumination thanks to automatic shutdown
- Ideal for additionally establishing radii and angles

- R/D switchable
- Axis parallelism compensation
- Linear and section compensation
- Formats for label and tool list printing
- Serial interface RS 232 for PC and other applications
- Parallel interface Centronics for printer
- Simple setup program
- Password protection

Additional measurement on Toolmaster 10-P and SMART

- Circle measuring 3-100 points by reticule
- Angle measuring 2-100 points per line

Technical Data

TM10-2D and TM10-P

Designation	Measuring range		L	H	Weight kg / lbs
	X-Axis (Ø)	Z-Axis (L)			
Toolmaster 10-2D	310 (12,2")	42-360 (1,66"-14,17")	650 (25,6")	814 (32,05")	65 / 143
	310 (12,2")	82-500 (3,23"-19,68")	650 (25,6")	977 (38,46")	70 / 154
Toolmaster 10-P	210 (8,27")	42-360 (1,66"-14,17")	635 (25,0")	814 (32,05")	75 / 165
	210 (8,27")	82-500 (3,23"-19,68")	635 (25,0")	977 (38,46")	80 / 176

Tool adapter available for ISO 40 or ISO 50

All dimensions in mm (inch)

Dimensions

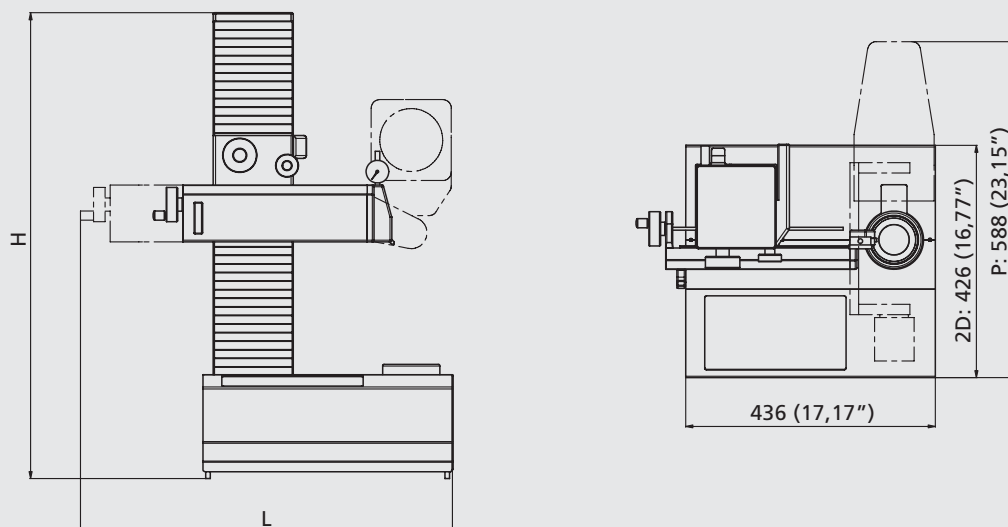

Power Supply

Electrics: 90-264 V AC/ 50-60 cycles

Compressed air: non required

Extent of Supply

- Basic unit, ready for operation
- Tool spindle ISO40 or ISO50
- Connecting cable
- Operator's manual
- Test certificate
- Guarantee certificate
- Dust cover
- One-way packaging

TM10-SMART Image Processing



TM10-SMART optimises tool presetting by using a fully electronic profile projector. The SMART image processor replaces the optical profile projector.

The digital CMOS-camera with telecentric objective probes the tool tip and transmits the live image to a transfective 3.5" TFT-colour display. The electronic maximum search allows the tip to be rotated through the maximum diameter (vertex). The measuring process is supported by positioning flags which appear when optimum congruence is achieved between tool contour and an axis of the reticule. Measurements can therefore be performed to a repetitive accuracy of +/-2 microns without operator involvement. The measuring process is extremely simple and is no different from the use of a profile projector. The operator consequently has no influence on the measuring result, thereby ensuring highest possible measuring reliability.

Any desired radius or angle can be displayed on the screen by means of a knob.

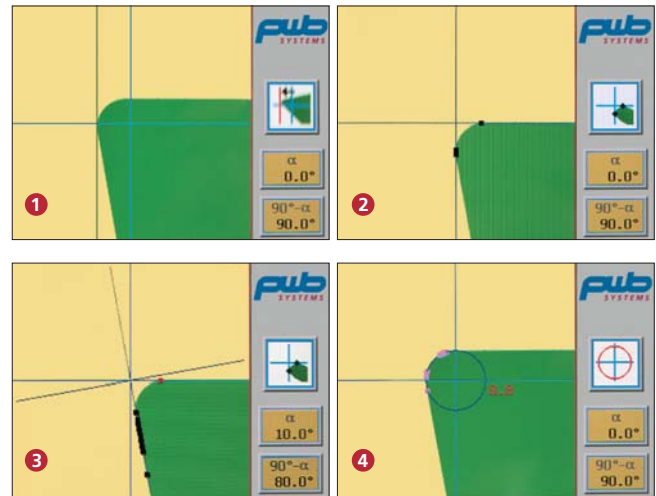

- 1 Maximum search facility. Largest diameter is indicated with a green line
- 2 Measuring process with position flag
- 3 Angle measurement
- 4 Radius measurement

Measuring Electronics TC 100 Compact intelligence



Technical data same as for TM10-2D and TM10-P

TM10-TCAM2 Image Processing



TM10-TCAM2 is the entry model for tool measuring with electronic image processing. It is the intelligent combination of a digital CMOS-camera and evaluation electronics with a 6.4" TFT-colour monitor.

TM10-TCAM2 can be used to align and position profile contours in X- and Z-axis as well as for manual measuring. Mouse operation makes it very easy to use. No time-consuming operator training is necessary.

The system possesses a high degree of built-in intelligence. Its automatic contour recognition recommends the most suitable measuring method to the operator and automatically displays the measuring lines and coordinates of the tip on the monitor.

Tool tip angles and radii are automatically displayed. An alpha-numerical keypad can be displayed on the screen and used by mouse click. As an option, a standard keyboard can be connected.

RS-232 interface for program updates and the documentation of measuring results in a computer network. As an option it is possible to transfer machine tool program compatible measuring data to a CNC control via RS-232 interface.

TM10-TCAM2 provides the operator with all data required for direct tool presetting. A PC is not required.

Measuring methods:

- fixed and floating axes
- reticule - centre

Measuring process:

- automatic recognition of measuring process by contour evaluation
- alternative manual determination of measuring process by mouse click

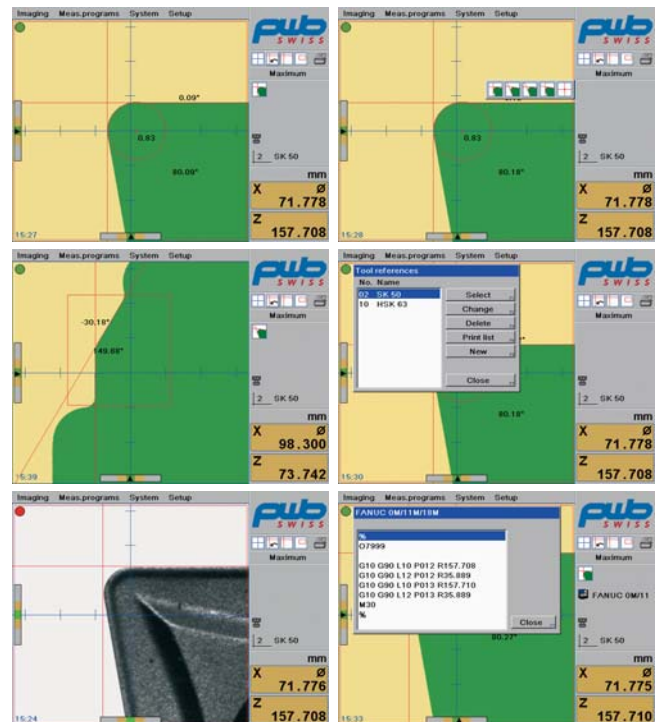

- 1 Measuring function with floating reticule
- 2 Manual selection of desired measuring process
- 3 Determination of measuring window
- 4 Management of adapter zero points
- 5 Frontal illumination for tip inspection (optional)
- 6 Control compatible data output (PP) (optional)

Measuring functions:

- line/angle/radius

Display and operating features:

- Adjusting aid for both axes
- Variable evaluation area, definable by mouse click
- Switchable live image, colour or black/white (tip inspection)
- Display hardcopy via RS-232 for documentation of measuring result
- Glass scales AcuRite 0.001 mm
- Memory for 99 adapter zero points
- Memory for 500 tools, 12 digits, alpha-numerical
- Internal tool library
- Absolute, difference and incremental measurements
- Switchable radius and diameter
- Switchable mm-inch
- Hold function
- Parallelism and linear compensation
- Password protection

Measurement output:

- Label and tool list via USB and RS-232
- Data output for 1 machine tool (optional)

Dialogue selection:

- English/German/French/Spanish/Italian (other languages on request)

Technical Data

TM10-SMART and TCAM2

Bezeichnung	Measuring range		L	H	Weight kg / lbs
	X-Axis (Ø)	Z-Axis (L)			
Toolmaster 10-SMART	250 (9,84")	42-360 (1,66"-14,17")	650 (25,6")	814 (32,05")	70 / 154
	250 (9,84")	82-500 (3,23"-19,68")	650 (25,6")	977 (38,46")	75 / 165
Toolmaster 10-TCAM2	250 (9,84")	42-360 (1,66"-14,17")	650 (25,6")	814 (32,05")	80 / 176
	250 (9,84")	82-500 (3,23"-19,68")	650 (25,6")	977 (38,46")	85 / 187

Tool adapter available for ISO 40 or ISO 50

All dimensions in mm (inch)

Dimensions

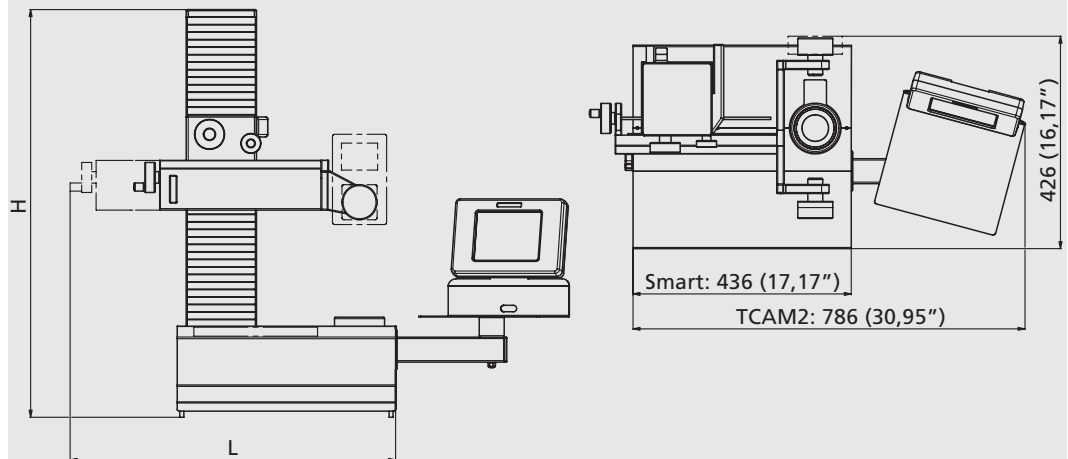

Power Supply

Electrics: 90-264 V AC/ 50-60 cycles

Compressed air: non required

Extent of Supply

- Basic unit, ready for operation
- Tool spindle ISO40 or ISO50
- Connecting cable
- Operator's manual
- Test certificate
- Guarantee certificate
- Dust cover
- One-way packaging

Accessories

All tool spindles, master mandrels and adapters are made of rust-resistant, vacuum hardened steel.



1 Master mandrel/wooden case

Master mandrels are for zero calibration and electronic error compensation of the guides (parallelism). Zero calibration is possible at any desired working height.

2 Adapter

Adapters are available for ISO/HSK/VDI and other tool systems.

3 Printer

- Needle printer for labels and tool lists
- Parallel printer cable 3 m (9,85 ft)
- Roll holder
- Labels 60 x 20 mm (2,36" x 0,787") (2000/roll)

4 WINPRESET

External PC software for evaluation and storage of measuring data from the presetter. Data transfer direct to machine tool, tool management system or DNC.

We reserve the right to make technical improvement.

Contact

Other Products



Toolmaster

- with pneumatic clamping
- with motorized adjustment
- with front illumination measuring functions
- with double camera systems
- special executions



Toolboy

Ergonomic tool assembly aid with variable tool inserts



Touchsetter

Easy determination of machine spindle reference point

pwb
SWISS

www.pwb-swiss.ch